

ASEISMIC DESIGN WITH PRE DEFINED PLASTIC HINGES- A STUDY

R. Sreekala^{*a}, N. Lakshmanan^a, K. Muthumani^a, A. Mehr Prasad^b and N. Gopalakrishnan^a

^aStructural Engineering Research Centre, CSIR, Chennai-113, India

^bDepartment of Civil Engineering, Indian Institute of technology, Chennai-36, India

ABSTRACT

This paper highlights the importance of selection of a suitable ductile composite, incorporating it into the predefined locations, for better seismic performance. Replacement of normal concrete with ductile composites at plastic hinge locations is an idea, which can be well thought for in the conceptual approach to structural design. A simple experimental investigation was carried out to establish this concept. The ability of the structure to sustain levels of inelastic deformation implicit in ductility values is dependent on the material and detailing used. Concrete, which is inherently brittle and weak in tension, were modified by incorporating polymeric materials like natural rubber latex and steel fibers. This improves ductility; strain at peak load and energy absorption capability. The validity of the scheme is proved by a couple of experiments including the stress- strain characteristics of the material as they play a significant role in ductile response of structural elements. Three point bending tests were conducted on four types reinforced concrete beams with different concrete matrixes at the central region and high strength concrete at other regions. As ductility and damage modeling of structural components plays an important role in achieving the performance objectives, they have been quantified using the experimental data by suitable methods. Damage index evaluation was done using one of the well-known damage models, which takes into account the hysteretic energy dissipation along with ductility. A response factor directly related to the damage index is found out in order to get the major design variable displacement ductility, thus helping the design stage calculations.

Keywords: Ductility; plastic hinge; stress-strain behaviour; energy dissipation; damage index

1. INTRODUCTION AND RESEARCH SIGNIFICANCE

The essence of conceptual design and detailing of structural elements forms the basis of the art of designing earthquake resistant buildings. It plays a prominent role in determining the structural behavior (before failure) and the earthquake vulnerability (sensitivity to damage) of

* Email-address of the corresponding author: kalachn@gmail.com (R. Sreekala)

buildings. Ductility capacity of structural elements has a key role to play in seismic design. The capacity design method is a simple and efficient approach to ductile structural design. In the case of ductile frames, it is desirable to have plastic hinges in the beams and not in columns because of the following reasons, 1) plastic hinges in the beams have larger rotation capacities than in columns; 2) mechanisms involving beam hinges have larger energy absorptive capacity on account of the larger number of beam hinges (with large rotation capacities) possible; 3) eventual collapse of a beam generally results in a localized failure, whereas collapse of a column may lead to a global failure; and 4) columns are more difficult to straighten and repair than beams in the event of residual deformation and damage.

The structural system should be so designed as to ensure that the formation of plastic hinges at suitable locations may, at worst, result in the failure of the individual elements, but will not lead to instability or progressive collapse. The engineering concept requires a ductile material, and the facility for the structure to deform plastically, at least at key locations. The ability of the structure to sustain levels of inelastic deformation, implicit in ductility values, is dependent on the material and detailing used. One of the suggestions often made is to improve the failure strain of concrete by confining reinforcement. It is also well known that inclusion of fibers in concrete matrix, and use of latex modified concrete improves the ductility of reinforced concrete elements. Suggestions are often made as to include these only at discrete locations where higher ductilities are needed, namely the plastic hinge locations.

The structural ductility and the structural performance factors depend on both the structural form selected and the materials used. In seismic design, the inelastic ductile behaviour is associated with energy dissipation upon load reversal, the latter being the fundamental mechanism counted upon to survive strong earthquakes. The inelastic response of beams in flexure plays an important role in the nonlinear behaviour of framed structures. In beam-column joints high percentage of transverse hoops in the core of the joint is needed in order to meet the requirement of strength, stiffness and ductility under cyclic inelastic flexural loading (Ehsani and White [1]). Several researches have reported the tests results using SFRC in framed beam-column joints (Tang et al. [2]). Damage indices are potentially valuable design tools as they provide means by which different design or retrofit options can be compared objectively. An experimental investigation has been undertaken on four types of reinforced concrete beams with different concrete matrixes at the central region and high strength concrete at other regions. The ductile behavior of the beam under three point bending involves the formation of a plastic hinge in the beam at the location where the new concrete matrix has incorporated. In addition to monotonic testing, reverse cyclic testing of structural components are very much necessary to understand the behavior of seismic actions (Kratzig et al. [3]). To correlate the damage process six repeated cycles were considered for given cyclic amplitude upto the ultimate deformation of the specimen. The damage index evaluated using Park and Ang model, mainly for hinged and HSC beams, were compared with that of shear dominant beams.

2. EXPERIMENTAL INVESTIGATIONS AND OBSERVATIONS

The materials chosen for the studies are one normal high strength concrete (HSC), fiber reinforced concrete (FRC) and natural rubber latex modified concrete with fibers (LMFC) for

two percentages of latex-DRC (namely 0.5 and 1.0). Earlier studies revealed that latex modification reduces the compressive strength of the concrete. To offset this strength reduction, steel fibres are added. Latex incidentally also helps in good fibre dispersion (Puwoei Chen et al. [4]). Latex modification improves the performance of the chosen mix with relatively larger strain at failure. Strain controlled cylinder tests were carried out to prove the efficacy of the mix. So, ductility of concrete is enhanced with the retention of strength level of plain concrete. The quantity of natural rubber latex can be expressed as the dry rubber content being the percentage by volume of concrete. The dry rubber content selected for the study is 0.5% by volume of concrete. The volume fraction of fibres used was 1%. Figure 1 shows the stress-strain characteristics of different concrete matrixes based on average of two specimens. These were obtained using the servo controlled universal testing machine with a closed loop control using lateral strain. The stress-strain characteristics were obtained using 200mm×100mm cylinder specimen. The peak stress, strain at peak stress, failure stress and failure strain for different concrete matrixes are shown in Table 1. During cylinder testing it was observed that for the same rate of loading till the failure, the time required to reach the ultimate strain from the peak is significantly high in the composites compared to HSC. While composites take 500-800 seconds from peak to failure HSC took only 50 seconds. This shows clearly its suitability in seismic resistant construction. The typical failure pattern of HSC was of brittle type but the modified composites exhibited a ductile failure which can be explained as follows. Detection of localization and analysis of bifurcated material are really essential keys of inelasticity of quasi-brittle materials. Higher volumetric compressive pressure leads to localized failures which was mentioned in experiments by Van Mier [5]. Hence the ductile composites shows localized failure patterns which have been proved by further tests on beams. Such property makes them suitable for retrofitting purposes.

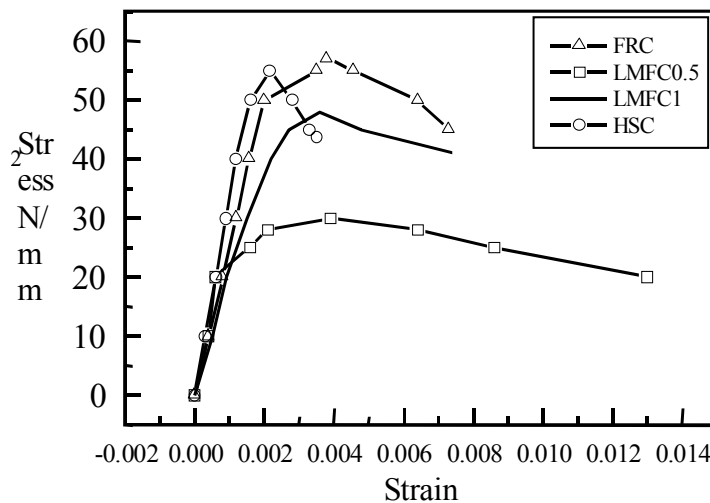

Figure 1. Experimental Stress strain curves

Table 1. Characteristics of Concrete

Sample No.	MATRIX	Peak		Failure	
		Stress (MPa)	Strain	Stress(MPa)	Strain
1	HSC	55	0.00216	43.75	0.0035
2	FRC	57	0.0038	45	0.0073
3	LMFC0.5	30	0.0039	20	0.013
4	LMFC1.0	48	0.0036	41	0.0074

The beam specimens had breadth of 100mm, depth of 150mm, and were tested over an effective span of 1.4m. In all the beams the central region of 300mm had different concrete matrices, and all other regions had high strength concrete. The beams were loaded with central concentrated load over simply supported span. Figure 2 shows the line sketch of beam test set up. Normally experimental investigations are undertaken wherein the stress-strain characteristics would be more or less similar, and tests would be conducted to determine the ductility. A slightly different approach is adopted in this paper to study the effectiveness of plastic hinge.

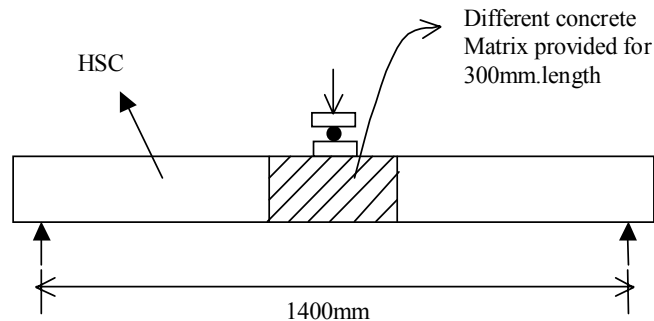

Figure 2. Line sketch of beam test set-up

The beams had an effective cover of 25 mm for HSC and FRC specimens, an effective cover of 50mm for LMFC 0.5, and an effective cover of 40mm for LMFC1.0. The beams were reinforced using 2-10# bars as tension reinforcement. 6mm diameter mild steel bars were used as stirrups. Detailing was done to avoid shear failure of the beams. The nominal 0.2% proof stress of the main reinforcement was 415 MPa. The stirrups hangers were also 2-10# bars provided with an effective cover of 30mm for all beams. Theoretical capacities were computed using the stress-strain curves of steel and concrete, and assuming linearity of strain across depth. The peak loads were computed as 25kN for HSC and FRC beams, 15kN for LMFC0.5 beams, and 18 for LMFC1.0 beams. Excepting for LMFC1.0, which showed a

peak load of 20kN, all other beams the peak loads, computed matched very well with the test results. For evaluating the ductility factor, the theoretical yield moment was computed using the relation.

$$M_y = A_s \cdot f_y \cdot (0.87d) \tag{1}$$

After evaluating the yield moment, the deflection at yield was taken from the load-deflection behavior of test beams. All the beams failed in flexure at the loading point. In static tests the beams were subjected to three-point bending tests in a displacement controlled test set up (MTS testing facility) till failure. The shear-span to depth ratio for all the beams was 4.5.

3. QUANTIFICATION OF DUCTILITY

It is proposed to compute the equivalent elastic load that the beams can withstand using the energy approach and the equal deformation approach. Figure 3 illustrates the determination of Equivalent elastic load (P_e)

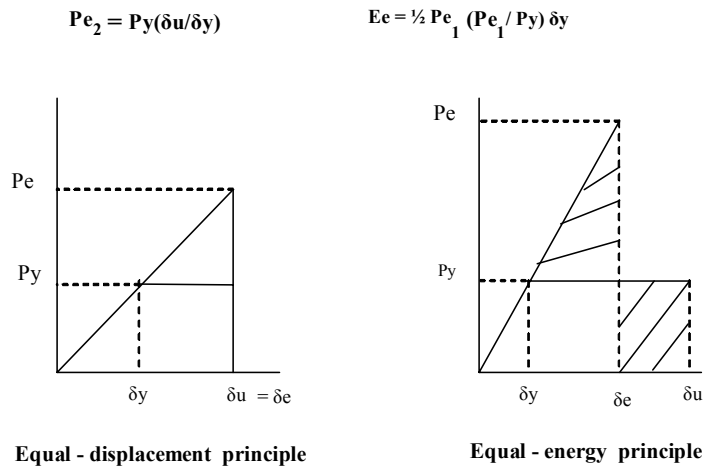

Figure 3. Equivalent elastic load determination

Assuming that load-deformation behavior is precise, the area enclosed by the P-Δ curve gives the energy. The equivalent stiffness is obtained as $(P_y/\delta y)$ where P_y and δy is the load and deflection corresponding to yield and P_e is the equivalent load determined corresponding to the ultimate deformation δu . Hence the energy of a linear elastic system with a load of P_{e1} is as

$$E_e = \frac{1}{2} P_{e1}(P_{e1}/ P_y) \delta y \tag{2}$$

$$P_{e1} = \sqrt{(2Ee.Py)} / \delta y \quad (3)$$

Equating this with the area of load –deflection plot the value of P_{e1} are obtained. The elastic load based on equal deformation approach is obtained as

$$P_{e2} = Py (\delta u / \delta y) \quad (4)$$

These values are tabulated in Table 2. it is observed from the results given in the table, that in the high frequency range, localized improvement is not that helpful . But in the long period and low frequency range, FRC, LMFC 0.5, LMFC 1.0- all the three concrete composites-when used in the plastic hinge region, have given around 50% enhancement in the peak elastic load P_{e2} as compared to HSC. Figure 4 shows the photograph of a typical failed specimen (hinged) under monotonic loading. The plastic hinge formed can be clearly seen.

Table 2. Equivalent elastic loads

Sl. No	Type	Area kN-mm	Stiffness kN/mm	P_{e1} , kN	P_{e2} , kN
1	HSC	478	2.44	48.29	62
2	FRC	657	2.50	57.30	99
3	LMFC0.5	814	1.63	51.52	92
4	LMFC1.0	600	2.40	53.67	94



Figure 4. Typical hinged beams-failure pattern under monotonic loading

In cyclic testing each displacement amplitude cycle was followed by five numbers of similar excursions before the next higher amplitude cycle was started. Cyclic testing was also done in a displacement controlled set up. Earlier Sadeghi et al. [6] has indicated that upto 20 repeated cycles of constant amplitude, the deterioration in strength stabilizes to a value similar to second cycle loading. Generally a maximum of two to four cycles are adequate to assess the ductility level of structural components by quasi-static test methods (Park [7] and Sheikh &

Khoury [8]). In the computation of displacement ductility, deformation at 15 percent strength reduction is taken as ultimate deflection (Rao et al. [9]). In the case of cyclic envelope, the average deflection at both the yield and ultimate points of the positive and negative phases has been considered in the computations. Table 3 shows the failure ductility values obtained from monotonic and cyclic loading tests. From the area of the monotonic envelopes, energy ductility also have been evaluated and the values are given in Table 3.

Table 3. Ductility of test beams

Type of Test	Description of Beams	Displacement Ductility (Monotonic)	Energy Ductility	Type of Beams	Cyclic Ductility
Monotonic -Three point bending Test	RCC	3.10	5.51	Full length	1.75
	FRC	4.45	7.56	Hinged	3.50
	LMFC 0.5	6.12	9.03	Hinged	5.42
	LMFC 1.0	5.24	11.66	Hinged	4.74

The average load deformation curve under cyclic loading of HSC and LMFC are given in Figure 5 and Figure 6. As HSC and LMFC 0.5 showed wide variations in ductility and energy absorption capability, only these two are illustrated. Latex modified hinged beams could withstand up to average cyclic amplitude of 30mm. For the HSC beam the corresponding value was 14mm. LMFC showed lesser rate of load drop with increase in cyclic amplitude. It is also observed that the rates of damage in the first few cycles at low cyclic amplitudes are higher compared to the later stages. After two or three cycles the area becomes constant in each amplitude.

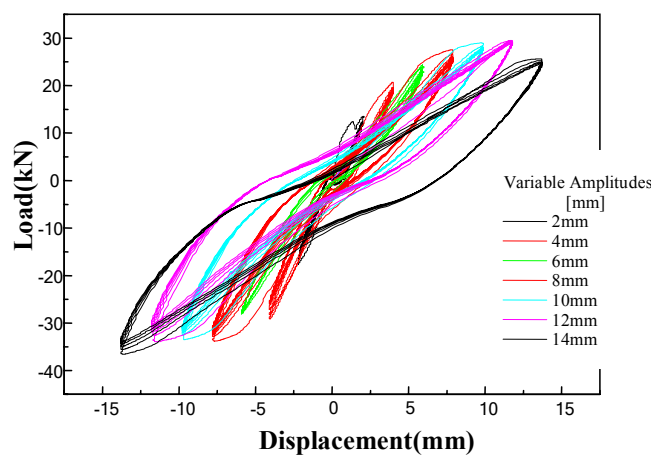

Figure 5. Load-deformation curve under cyclic loading-HSC

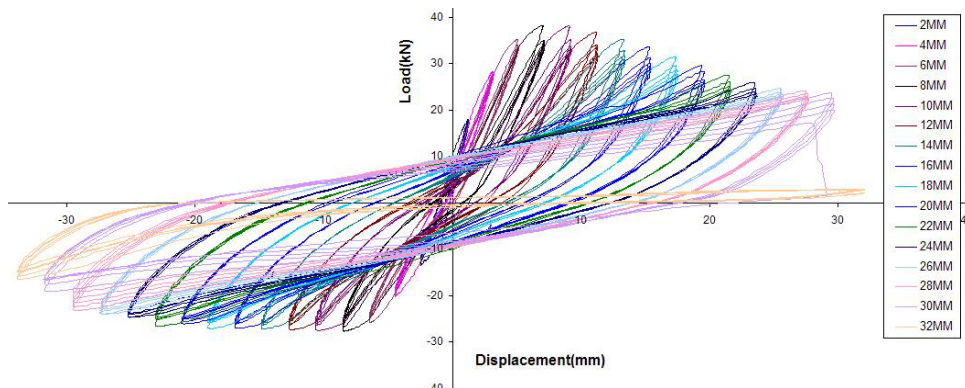

Figure 6. Load –deformation curve under cyclic loading-hinged beams

4. DAMAGE INDEX EVALUATION

Energy dissipation capacity of a structural member and therefore of a structure, depends upon both the loading and deformation paths. Thus experimental determination of the energy dissipation capacity of the main elements and their basic sub assemblages as a function of maximum deformation ductility is very important. The damage index proposed by Park and Ang [10] for reinforced concrete elements is the one most widely used in the technical literature. It is expressed as a linear combination of the normalized maximum deformation and the normalized hysteretic energy

$$D = \frac{\delta m}{\delta u} + \frac{\beta}{F_y \delta u} \int dE \quad (5)$$

in which D =damage index ($D > 1$ indicates excessive damage or collapse)

δm =maximum deformation under earthquake

δu =ultimate deformation capacity under static loading

F_y =calculated yield strength

dE =incremental hysteretic energy and

β =parameter accounting for cyclic loading effect - a constant that depends on the structural characteristics.

From the hysteresis loops the energy dissipated under cyclic loading has been evaluated. The experimental results from the monotonic and cyclic have been utilized in the evaluation of damage index using Park and Ang model and the damage curves are given in Figure 7. A comparison with the damage curve of shear dominant beams developed by Rao et al. [9] can also be seen in Figure 7. The results indicated that for shear dominated tests, the damage sustained is primarily dependent on the deformation level, with the number of cycles having small effect. The reduced damage observed in hinged beams for a particular level of ductility ratio as seen in the Figure 7 is a definite advantage.

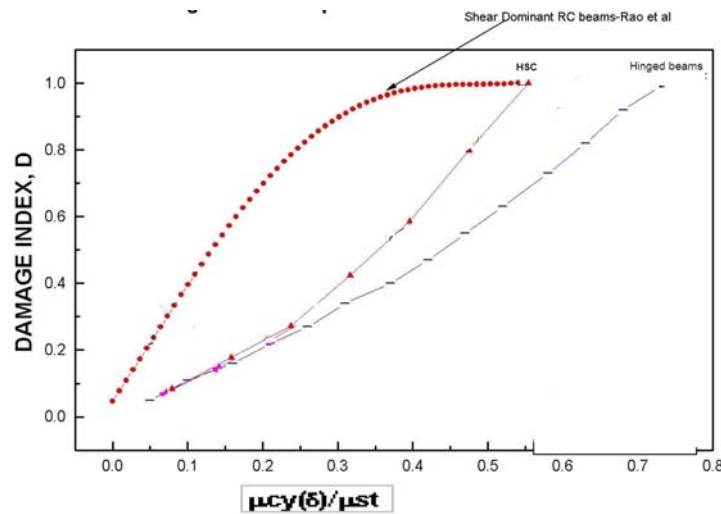

Figure 7. Damage index comparison between hinged beams and HSC

The ratio of static to cyclic ductility can be directly related to damage index which helps in the design stage calculations for known/assumed damage levels.

5. CONCLUSIONS

A simple experimental investigation on predefined plastic hinges with the ductile composites namely LMFC and FRC revealed their potential in ductile design of structures. Static and cyclic experiments were conducted on four types of reinforced concrete beams having different concrete matrices in the central region to a length of 30 cm which represents two times the overall depth of the beam. This region essentially represents the plastic hinge location, in simply supported reinforced concrete beam elements, under single point loading at centre of span. The equivalent elastic loading using energy equivalence is nearly the same for all the four beams. With the equal displacement approach, valid for long period structures ($f_n < 2\text{Hz}$), there is definite advantage. The increased energy dissipation capacity and large failure ductilities of the replaced hinge-latex modified fibre concrete-beams is helpful in earthquake resistant design of structural members. The damage index have been evaluated using Park and Ang damage model. The quantification of ductility and damage have been carried out to aid the design stage calculations. A response factor directly related to the damage index can be found in the unified approach in order to get the major design variable displacement ductility.

REFERENCES

1. Ehsani MR, White JK. Confinement steel requirements for connections in ductile frames. *Journal of the Structural Division, ASCE, ST12* **96**(1990) 751-67.

2. Tang Jiruree, Chaobin, Yag Kaijian, Yan Young Cherh. Seismic behaviour and shear strength of framed joint using SFRC. *Journal of Structural Division ASCE*, No. 2, **118**(1999) 341-35.
3. Kratzig WB, Meyer IF, Meskouris K. Damage evolution in reinforced concrete members under cyclic loading. *Proceedings of the International Conference on Structural Safety and Reliability*, San Fransisco, **Vol. 2**, 1989, pp. 795-802.
4. Chen P-W, Fu X, Chung DDL. Microstructural and mechanical effects of latex, methylcellulose and silica fume on carbon fibre reinforced cement. *ACI Materials Journal*, No. 2, **94**(1997)147-55.
5. Van Maier JGM. Fracture of concrete under complex stress. *HERON* 31:1-90
6. Sadeghi K, Lamirault J, Sieffert JG. Damage indicator improvement applied on R/C structures subjected to cyclic loading. *Proceedings Second EUROLYN*, 1993, pp. 129-136.
7. Park R. State of the art report-ductility evaluation from laboratory and analytical testing- *IX WCEE Proceedings*, Tokyo, Japan, Vol. **3**, 1988, pp. 605-616.
8. Sheikh SA, Houry SS. Confined concrete columns with stubs. *ACI Structural Journal*, No. 4, **90**(1993) 414-31.
9. Rao PS, Sharma BS, Lakshamanan N, Strangenberg F. Damage model for reinforced concrete elements under combined loading. *ACI Material Journal*, December (1998) 682-90.
10. Park YJ, Ang AHS. Mechanistic seismic damage model for reinforced concrete, *Journal of Structural Engineering*, ASCE ST No-4, **111**(1985) 722-5.