

## **A STUDY OF MEASUREMENT AND ADMINISTRATIVE MAINTENANCE INFORMATION SYSTEM OF CIVIL ENGINEERING STRUCTURES USING OPTICAL FIBER TECHNOLOGY**

M. Nakano<sup>\*a</sup>, M. Okuno<sup>b</sup> and Sh. Katagiri<sup>c</sup>

<sup>a</sup>Department of Civil Engineering, Osaka Sangyo University, Japan

<sup>b</sup>Technical Division, NTT Infrastructure Network Corporation, Japan

<sup>c</sup>Department of Civil and Environmental System Engineering, Setsunan University, Japan

### **ABSTRACT**

In recent years, the Information Technology (IT) has been utilized in various fields of civil engineering. Especially, trials have been made to utilize optical fibers as sensors to measure strain of civil engineering structures, ground deformation, temperature, etc., and they have been installed for measuring in the civil engineering structures including tunnel, river embankment, and cut-slope soil structures. In order to make such optical monitoring systems of civil engineering structures more general and organic systems, it would be effective to combine them with such comprehensive telecommunication systems. The infrastructure structure measurement and maintenance system is accumulation and collection system and processing/offering/exchanging system, and the network where information is additionally transmitted is needed. We investigate the construction of general monitoring systems of civil engineering structures which can perform thorough management from monitoring to maintenance utilizing telecommunication networks technology.

**Keywords:** Civil engineering structure; optical fiber sensor; botdr; monitoring system; maintenance management

### **1. INTRODUCTION**

#### *1.1 Maintenance control of civil engineering structure [1-2]*

At present, for dangerous places or for checking soundness or damage conditions of public infrastructure structure at occurrence of any disaster or accident, we depend, in most cases, on image monitoring through visual checking, ITV cameras, etc., but the following problems can be enumerated.

---

\* Email-address of the corresponding author: nakano@ce.osaka-sandai.ac.jp (M. Nakano)

- Difficulty of continuous monitoring of facilities or structures to be checked
- Difficulty of quantitative judgment of soundness
- Difficulty of predicting disaster occurrence
- Dangerous work involved
- Difficulty of information collection at the time of a wide-area disaster

### *1.2 Optical fiber sensor technology*

Optical fibers are widely used as transmission media capable of handling mass communication, but in addition to the communication function, they can also be used for measuring strain occurring in the longitudinal direction of the optical fibers by utilizing the backscattering occurring in the optical fibers. Features of the optical fiber sensor (hereinafter referred to as BOTDR) are cited as follows.

- While the conventional electrical strain meter can only obtain discrete information of point measuring, the BOTDR using the optical fiber itself as a sensor can obtain continuous data in the longitudinal direction, and it is possible to comprehensively measure a surface depending on the wiring form.
- It does not require power supply to the sensors and is not subject to electrical induction of thunderbolts, power cables, etc.
- Low loss characteristic of the optical fiber makes it possible to remotely monitor points to be measured.
- If any optical fiber sensors are damaged at the measuring points, partial replacement is possible.

We introduce application cases of the BOTDR expected as sensing technology capable of large-scale continuous line or surface observation and also describe general monitoring systems of road facilities utilizing the IT technology.

## **2. PRINCIPLE OF BOTDR**

Light incident upon optical fibers is scattered in the propagation course through the optical fibers due to small fluctuation in density and composition of the glass. When light pulses are put into the optical fibers, the Brillouin scattered light occurring in the optical fibers has a particular power spectrum (frequency distribution) and the power spectrum shifts in proportion to the longitudinal expansion/contraction (strain) of the optical fibers. By detecting the frequency shift amount, relative strain amount is calculated. The strain occurrence position is specified by the time from pulse incidence upon the optical fibers and return of the scattered light. This makes it possible to obtain the deformation (strain) of a measuring point as continuous data by installing the fiber-optic cable at the measuring point, Figure 1.

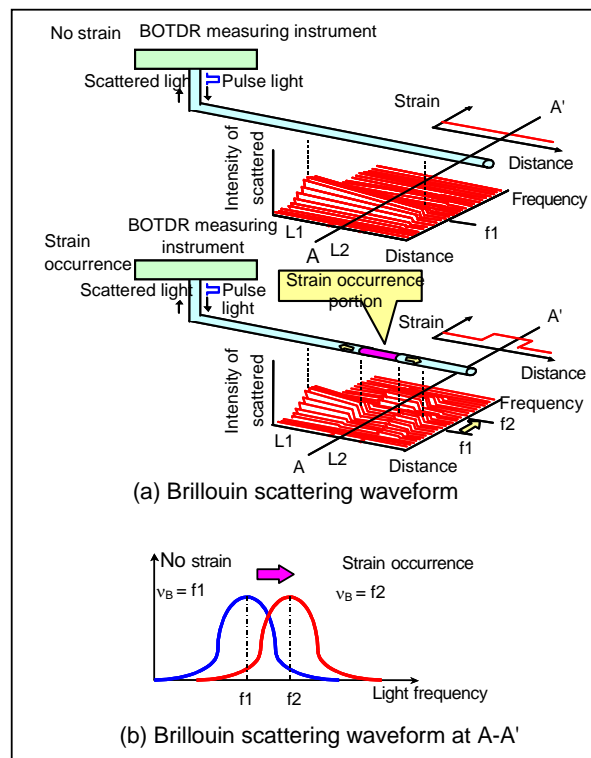

Figure 1. Strain measuring principle through BOTDR measurement [3]

### 3. CASES OF MEASURING CIVIL ENGINEERING STRUCTURES

We describe cases of measuring behavior of civil engineering structures by the type of structure on which measurements have been carried out using the BOTDR.

#### 3.1. Road structure

A problem often encountered when various pipelines are buried under roads is how to measure the subsidence of the road surface and retaining wall back roadbed. As a result of these measuring cases, it is confirmed that the application of BOTDR is possible for measuring at a relatively shallow position. It is effective for monitoring road structures having a line or surface extension and it is expected to make more efficient and enhance the maintenance and management operations, Figure 2.

#### 3.2. River embankment structure

In order to monitor the collapse and unequal subsidence of embankments due to localized torrential rain, earthquake, etc., optical fibers are installed in the axial direction of embankment and the movement of the embankment body is measured with the BOTDR. This makes the best use of the feature of the BOTDR that the longitudinal measuring can be continuously done, Figure 3.

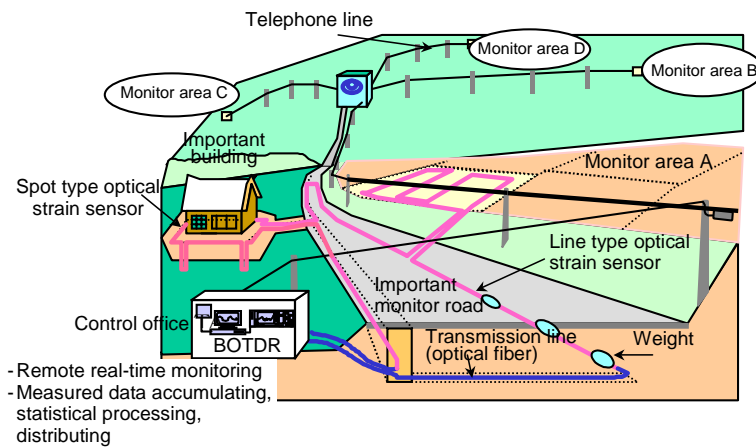

Figure 2. Road Construction monitoring image through BOTDR measurement



Figure 3. Installation of optical fibers

Embankment collapse is considered to be caused by the fact that the increased degree of saturation of the embankment earth due to permeation of river water/rainfall decreases the shear strength of the earth. Erosion starts at the toe of slope resulting in sloughing, and the collapsing earth gradually moves to the lower side of the slope subsequently leading to the embankment. break. The optical fiber sensors are, therefore, installed in the same direction as the movement direction of the embankment earth so that the embankment deformation can be accurately detected (Figure 4). In experiments using a dummy embankment, strain was measured with the optical sensors before the collapse of the face of slope was visually confirmed, showing high possibility of using the optical sensors for detecting signs of embankment collapse.

River management has involved dangerous work, day or night, in an emergency such as flood or earthquake, and even in the daily patrol checking, the extension is very long, requiring lots of labor and time. Using the BOTDR for continuous monitoring of an embankment makes it possible to quickly judge leakage or embankment deformation to quickly cope with it, and it is expected to have a significant meaning even in the daily



Figure 5. An example of screens for monitoring river embankment collapse

### 3.3 Tunnel structure [4]

The space under roads has been utilized in various ways for preparing and improving lifelines to support a pleasant urban life and also communication networks for the advanced information-oriented society. At present, many new structures are being constructed near existing structures. Here we introduce a case where the BOTDR is utilized for measuring effects of construction of a subway station building on an existing shield tunnel, Figure 6.

Within the tunnel, sensors are installed in both the longitudinal and traverse directions, and in the longitudinal direction, they are installed on both upper and lower sides in consideration of a decrease in upper earth pressure of the tunnel due to the construction of the station building, and in the traverse direction, they are installed in both vertical and horizontal directions so that the cross-sectional deformation of the tunnel can be accurately judged, Figures 7 and 8.

Now, the excavation work for the construction of the subway station building has been completed, and Figures 9(a) and 9(b) shows the BOTDR measuring situation at the time of excavation completion. With the sensors in the longitudinal direction, the tunnel deformation due to the ground improvement is clearly detected, and with the sensors in the traverse direction, flattening upward of the tunnel due to the decrease in upper earth pressure due to the progress of excavation is detected. The measurement situation has so far been in agreement with the predicted deformation mode showing that this system accurately measures the tunnel behavior. The measuring accuracy is judged to be 30 to 50 $\mu$ . By the existing measuring method, it was difficult to accurately monitor three-dimensional behavior of the entire structure because of a blank area of measurement due to economic restrictions such as equipment and maintenance costs, but the measuring system utilizing the BOTDR realizes accurate and continuous deformation monitoring. In some cases, the BOTDR is used for measuring when a tunnel is constructed by NATM method and monitoring the behavior of a shared road tunnel. For measuring during tunnel construction, the stress conditions of peripheral ground is monitored with optical fibers inserted in the steel pipe first received and also the stress conditions of the steel and concrete are always monitored with optical fibers installed in the timbering and sprayed concrete. These realize continuous data collection, which was difficult with the conventional electrical strain meter.

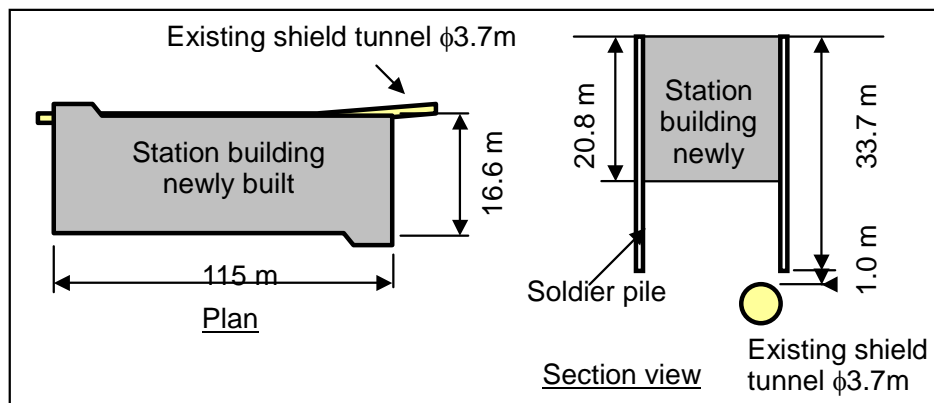

Figure 6. Proximity situation

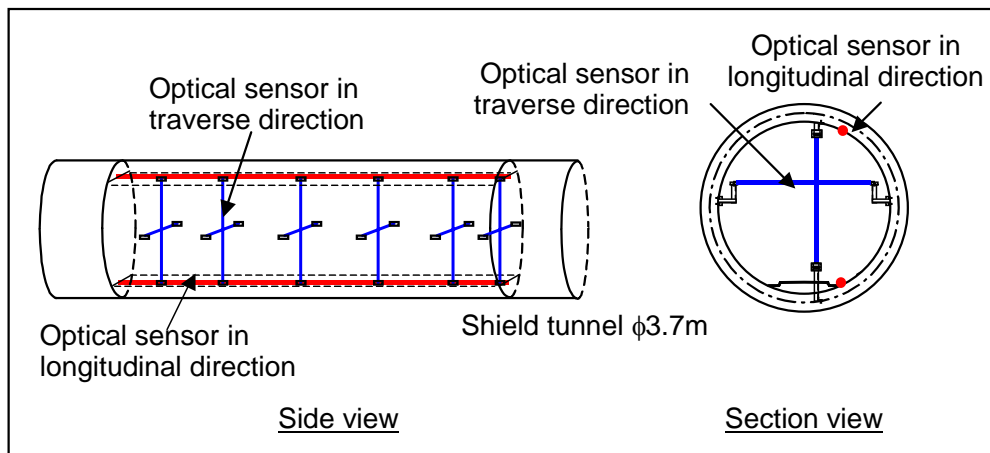
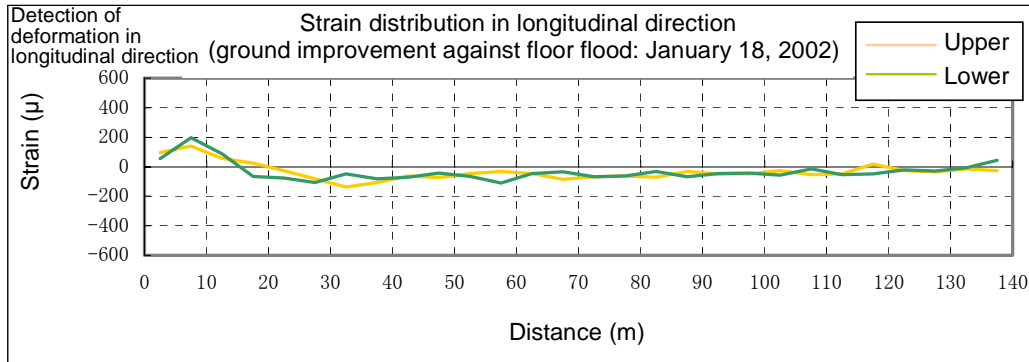

Figure 7. Installation of optical fiber sensors



Figure 8. Installed condition of optical fiber sensors



(a) Measuring in longitudinal direction of shield tunnel

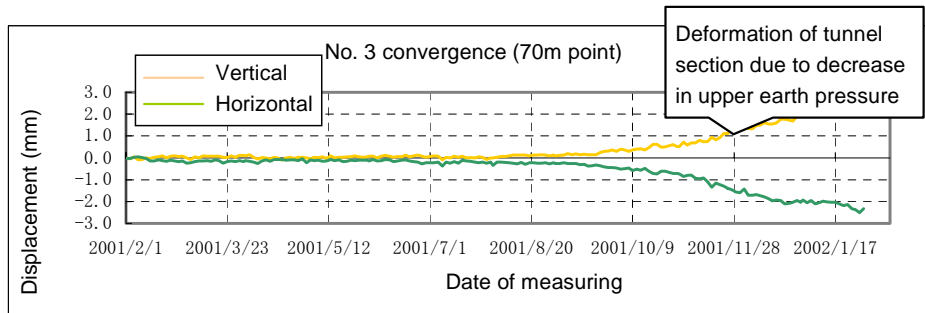

(b) Measuring in traverse direction of shield tunnel

Figure 9. Measurements of a shield tunnel

### 3.4. Soil structure

For easy-to-slide ground, such as a road bank or slope, movement is monitored by inserting a pipe with optical fiber (optical strain meter) attached, and groundwater level (optical water level gauge) and ground cracking (optical extensometer) are measured with the BOTDR in some cases, Figure 10. With the pipe strain meter using the conventional strain gauge, it was difficult to accurately specify the sliding surface because of the limited number of sensors installed, but by using the optical fiber as a sensor, it becomes possible to acquire continuous data, thus making it possible to accurately specify the sliding surface, Figure 11. Measured data are accumulated in the control office and corrected/converted, and visualized measurement results are shown on the display. Furthermore, the data are distributed to Web servers, and thus the system is utilized as a disaster prevention system that can supply the information to those concerned via the Internet, Figure 12. In addition, on a slope with the danger of collapse, optical fibers are continuously installed to the prevention net for falling stone, and rock collapse is monitored through the net behavior. The BOTDR realizes continuous data collection at a place where daily checking is impossible or a place that does



not allow human access, and it is expected as a system to prevent disasters and minimize damage through a reinforced monitoring system for disaster prevention and accurate maintenance support.



Figure 10. Installation of optical pipe strain meter

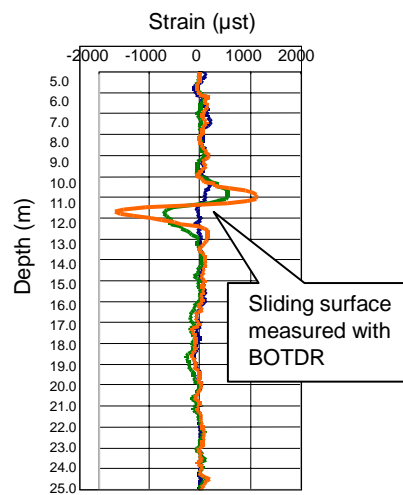

Figure 11. Measuring with optical pipe strain meter

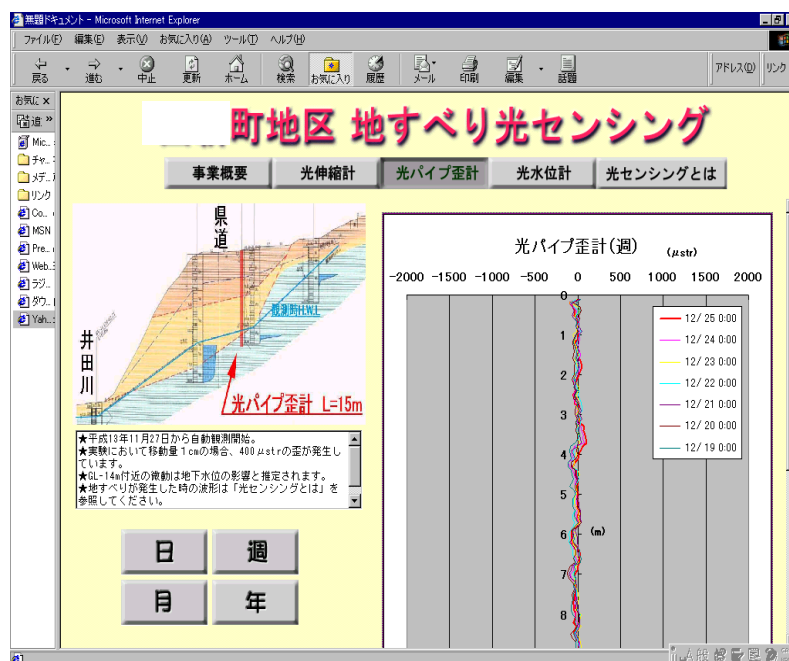

Figure 12. Opening to Internet

The above has described some cases of actual application to civil engineering structures, and in the future, we think it will become possible to stabilize urban supply functions and improve the efficiency of maintenance management by measuring strain and temperature changes at various places of lifeline structures including railroad, water supply and sewerage, gas, electricity, and communication facilities.

#### 4. OPTICAL MONITORING SYSTEM OF CIVIL ENGINEERING STRUCTURES

As integrated systems of people, roads, and vehicles using the most advanced information technology, IT (Information Technology) is now being constructed to enhance the navigation system, establish an automatic charge paying and receiving system of toll roads, etc., support safe driving, optimize traffic management, and promote the efficiency of road control, and improve safety, transportation efficiency, and comfort. By organically combining such IT with the optical monitoring system of civil engineering structures, it becomes possible to construct the general monitoring system utilizing IT [5-6].

By connecting infrastructures maintenance information with optical fibers laid at potential disaster places, it becomes possible to overcome physical and geographical among disaster places. A structure information controller can quickly obtain desired information, 24 hours a day, at the central control office, predict disaster occurrence, and promote efficient maintenance and control operations. Figure 13 shows an application image of the optical monitoring system using the optical fiber network [7-9].

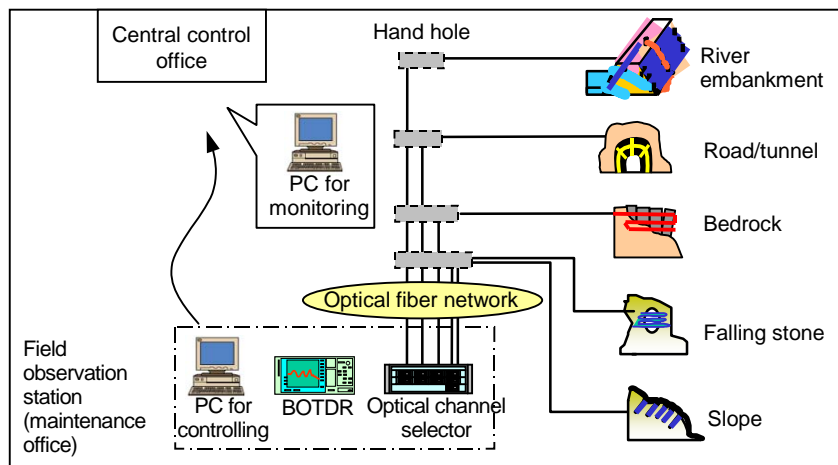

Figure 13. Image of optical monitoring system of civil engineering structures

## REFERENCES

1. Mahoney W. An Advanced Weather Information Decision Support System for Winter Road Maintenance Proceedings of 8th World Congress on ITS, Sydney, 2001.
2. Kutsukake T. Role that road played in a time of disaster Traffic Engineering, No. 3, **40**(2005) 19-23.
3. Kurashima T, Tanaka K, Usui T. Strain Distribution Measuring Using Optical Fibers, Symposium on Rock Mechanism, *Japan Society of Civil Engineers*, January 1997.
4. Okuno M, Shimagaki T, Seki R, Nagano M, Tanaka K, Sakata E. Tunnel Monitoring System Using BOTDR Technology Institute of Electronics, Information and Communication Engineers, Optical Fiber Application Technology Research Society, January 2002.
5. Nakano M, Yano K. General Management Network System in Road Disaster Prevention Field Utilizing Information Technology, Proceedings of 8<sup>th</sup> World Congress on ITs Sydney, 2001.
6. Nakano M, Tsuda T, Matsushige N, Sasaki S, Sakata E. General Monitoring System of Civil Engineering Structures Utilizing Information Technology, Japan Society of Civil Engineers, Civil Engineering Information System Committee, October 2001.
7. Nakano M, Katagiri S, Okuno M. Development of PE-Pipe Optical Fiber Sensor for Observation of Ground Deformation, *Journal of Applied Computing in Civil Engineering 2008*, **17**(2008) 83-90,
8. Kobayashi W, Obata H, Hashimoto Y, Narita K. Development of platform system for infrastructure management by geospatial information, *Journal of Applied Computing in Civil Engineering 2008*, **17**(2008) 257-62.
9. Takahashi S, Tamura M, Yamamura Y, Kojima M. A Study of a Safety Support System that uses Information from the Road Infrastructure No. 3260, Proceedings of 11th World Congress on ITS, Nagoya, 2004.